



AVIATION LIGHTING

Design, Manufacture, Supply Airfield Lighting and Obstruction Lighting Products
EM: contacto@helipuerto.cl

HL-200 LED Elevated Heliport Floodlighting

HL-200 LED Heliport Floodlight is proved to be reliable quality and widely used at all kinds of helipads, rooftop, surface ground, shipboard, and helidecks. It shall be located so as to avoid glare to pilots in flight or personnel working on the area. Floodlighting system ensure the helipad surface illumination not less than 10 Lux.

Applications:

- Elevated mounted illuminated TLOF/FATO area.
- Winching areas.
- Parking areas.

Compliant:

- ICAO Annex 14, Volume II, 4th Edition, July, 2013
- FAA AC150/5390-2C

Why HL-200:

- Lens hood reduce the glare to pilots.
- Fixture can be used with 100V~250V AC, 50Hz or 60Hz.
- Low profile, lowest adjustable less than 20cm in height.
- Cost effective solutions.
- Rating IP65.

LED & Electrical Characteristics:

- Color temperature 6000K.
- LED light source 50,000 hours lifetime.
- Luminous flux 2600Lm.
- Power by 100V to 250V AC, 50Hz or 60 Hz.
- 30 W power consumption.

Drawings:

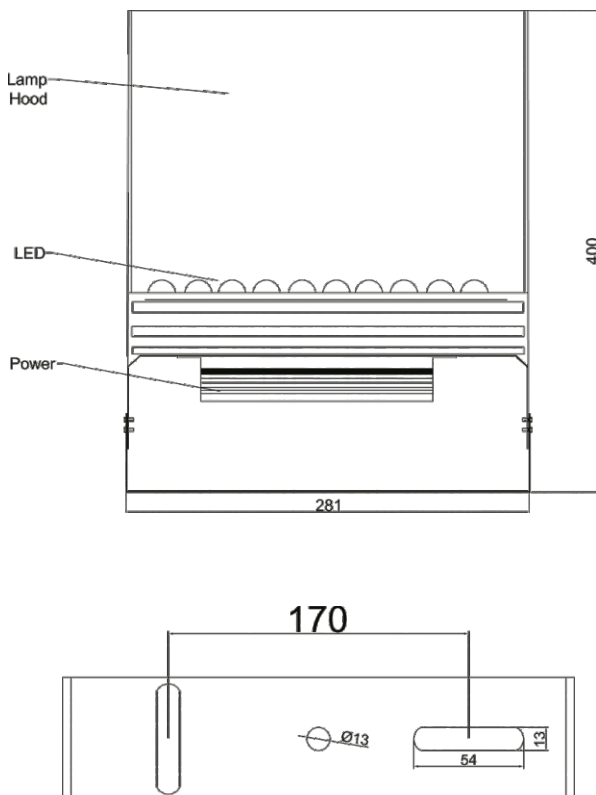

Physical Characteristics:

- Steel housing made.
- Grey powder coating finish.
- Impact resistant polycarbonate lens cover.
- Lay size: 40cm×28.1cm×8.5cm.(15.7"×11"×3.3")
- 17cm-M12×2 for mounting details.
- 3.5KG net weight.

Environmental:

- Operating at -40°C to 60°C.
- Wind speed: 80m/s.

Ordering codes:

Type	Output	Lamp	Finish
HL-200	W: White	AC: 100/250V ¹ DC: 10/30V ²	Grey standard color. Yellow power coating.

¹ Operation at AC100V to 250V, 50Hz or 60Hz.

² Operation at DC10V to 30V, 50Hz or 60Hz.

Project:

